

THIS DRAWING IS UNPUBLISHED. RELEASED FOR PUBLICATION  
 BY AMP INCORPORATED. ALL RIGHTS RESERVED.

Loc		DIST		REVISIONS			
P	LTR	DESCRIPTION		DATE	DWN	APVD	
FT	8	N		REDRAWN W/O CHANGE PER EC 0320-98-96	24 NOV 97	-	-

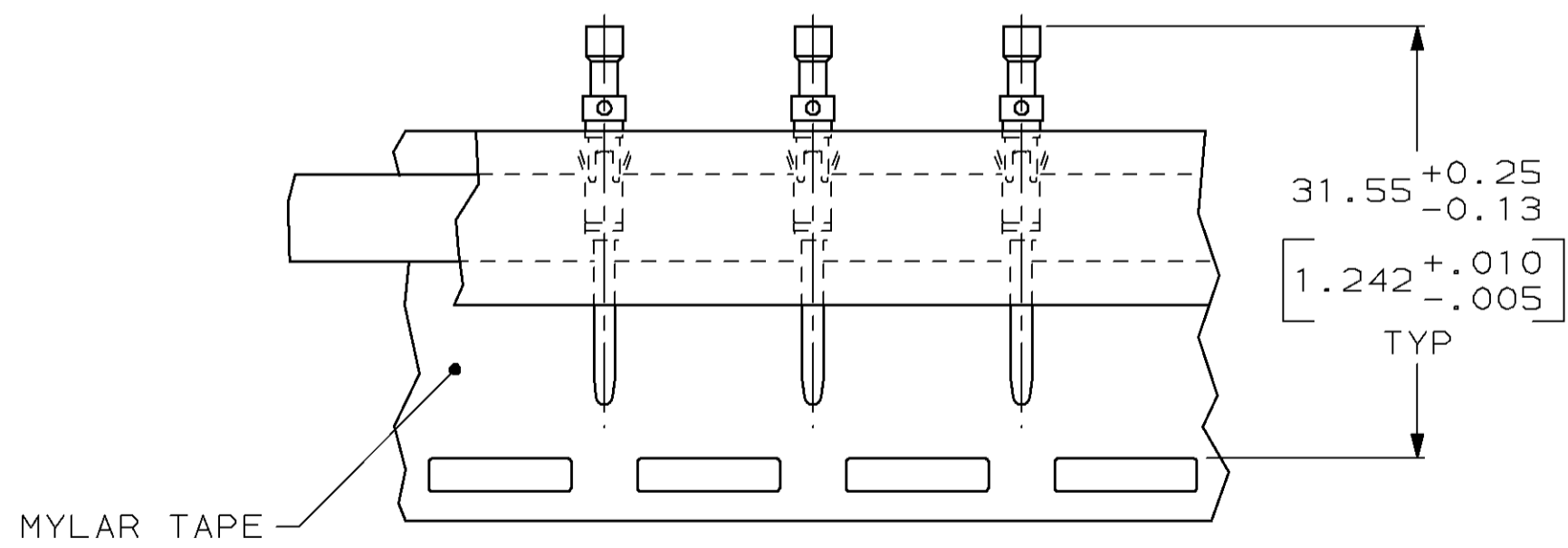
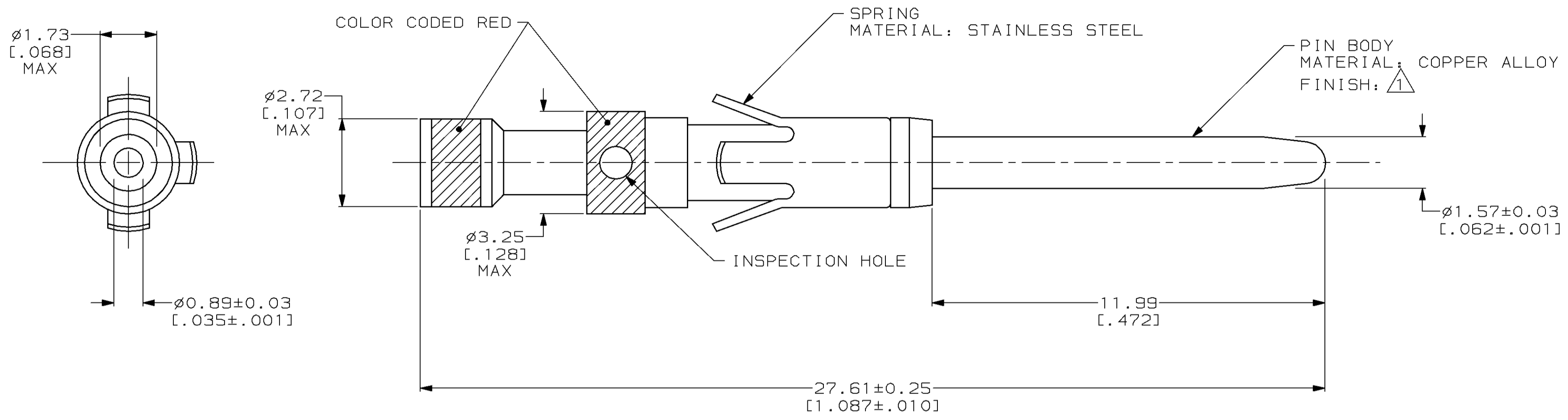

- 1 0.76µm [0.000030] MIN GOLD OVER 1.27µm [0.000050] MIN NICKEL.
- 2 WHEN ORDERING CONTACT ASSEMBLY ON TAPE, ORDER BY THE TAPE NUMBER PLUS THE PACKAGING CODE AS FOLLOWS:
  - 1. FOR USE WITH AMP TAPETRONIC, PNEUMATIC TOOL-
    - A. 1000 PARTS TO A BOX ADD PACKAGING CODE: 1MBOX
  - 2. FOR USE WITH 4/8 INDENT STRIPPER CRIMPER-
    - A. 1000 PARTS TO A REEL ADD PACKAGING CODE: 1MREEL
    - B. 5000 PARTS TO A REEL ADD PACKAGING CODE: 5MREEL

TAPE MTD	201611-4
STANDARD	201611-1
PACKAGING TYPE	PART NUMBER

THIS DRAWING IS A CONTROLLED DOCUMENT.		DWN	24 NOV 97	<b>AMP</b> AMP Incorporated Harrisburg, PA 17105-3608			
DIMENSIONS: mm [INCHES]		CHK	09 DEC 97				
TOLERANCES UNLESS OTHERWISE SPECIFIED:		APVD	16 DEC 97	CONTACT ASSEMBLY, PIN, #16, 24-28AWG, TYPE II			
0 PLC ±-		NAME	G. STEINHAUER				
1 PLC ±-		PRODUCT SPEC	-	SIZE	CAGE CODE	DRAWING NO	RESTRICTED TO
2 PLC ±0.13 [0.005]		APPLICATION SPEC	-	A2	00779	201611	-
3 PLC ±-		WEIGHT	-	SCALE	10:1	SHEET	1 OF 1
4 PLC ±-		FINISH	-	CUSTOMER DRAWING		REV	N
ANGLES ±-							
FINISH							
SEE CALLOUTS							

201611

B

A